

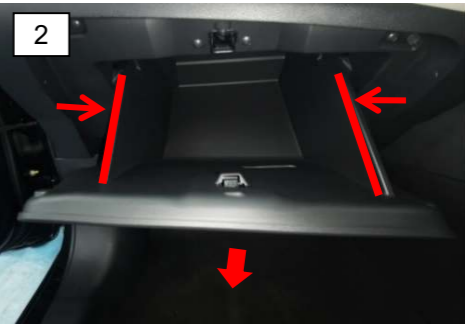













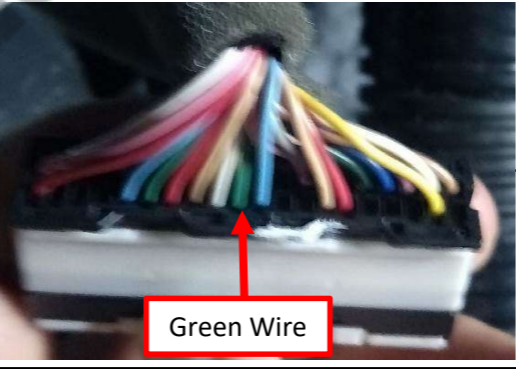

| | | | | | | |
|---|--|---------------|-------------|------------|--|--|
| OPERATION NAME NISSAN ALMERA L02D SPEED LOCK INSTALLATION | SAFETY FIRST (EQUIPMENT & INSTRUCTION) - Make sure disconnect Negative(-) Terminal and then wait at least 3 minutes - Make sure hand hold connector when unplugging - Ensure 'click' sound when plug in connector | VITAL PORTION | DATE | 21/10/2021 | | |
| | | | PREPARED BY | WY NG | | |
| | | | MGR OK | NATHAN LOW | | |
| | | | GK OK | | | |

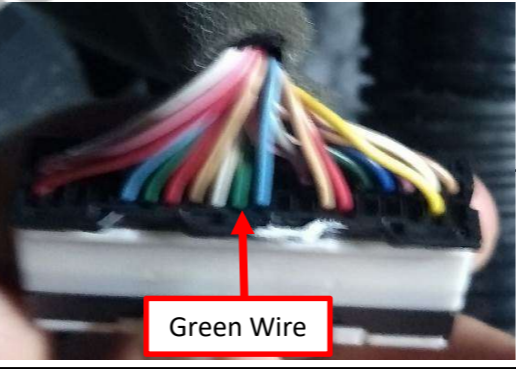
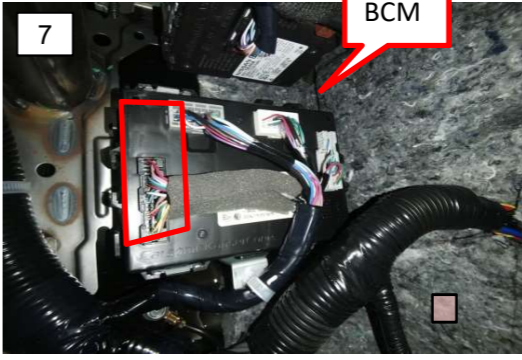
| NO. | MAIN STEP | TIME | KEY POINT | REASON | DRAWINGS/PHOTO/PROCEES FLOW |
|-----|---|------|---|--|---|
| 1 | Use M10 spanner to open the nut at GND battery. Removed the terminal and place at side of the battery wall. | | Note: Ensure the GND terminal is not moving. | |  |
| 2 | Open the glove box by press in the both wall as shown. | | Note: Ensure the blocker is removed out only pull out the glove box. | |  |
| 3 | Remove the glove box by pulling it out as shown. | | | |  |
| 4 | Remove 6 x screw as shown. | | Note: Ensure bottom 2 screw have washer | Bottom Left  Bottom Right  |  |
| 5 | Remove left side instrument panel as shown. | | Note: Ensure the hook is attached, when the screw is removed it easily drop out. Place it back when it drop out to prevent missing. |   |  |
| 6 | Disconnect the device as shown. | | |  |  |
| 7 | Find for the black color connector and disconnect it. | | |  |  |
| 8 | Tap the green color wire from the supply T-joint wire to the 71 pin (green color) of the black connector. | |  |  |  |

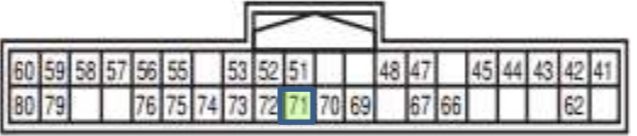
| | | | | |
|---------------|--|----------------|------------|---|
| DOCUMENT NO.: | TOOLS USED | MATERIALS USED | PARTS USED | SHEET NO. 1 <hr/> 2 |
| REVISION NO: | Spanner No 10 | | | |
| ISSUE DATE: | Removal tool, plier Screwdriver "+" | | | |



OPERATION NAME
**NISSAN ALMERA L02D
SPEED LOCK INSTALLATION**

SAFETY FIRST (EQUIPMENT & INSTRUCTION)
- Make sure disconnect Negative(-) Terminal and then wait at least 3 minutes
- Make sure hand hold connector when unplugging
- Ensure 'click' sound when plug in connector

| | |
|---------------|------------|
| VITAL PORTION | |
| DATE | 21/10/2021 |
| PREPARED BY | WY NG |
| MGR OK | NATHAN LOW |
| GK OK | |

| NO. | MAIN STEP | TIME |
|-----|--|------|
| 9 | Connect the supplied T- joint wire to the OE Connector as shown. | |
| 10 | Connect the Speed Lock Module and the OE Device to the T-joint wire. Note: Connect the Speed Lock Module to the connector that come with "Speed Lock" sticker. | |
| 11 | Sticker the module to the cover as shown Make sure the module is not blocking with other part when install back the left side instrument panel. | |

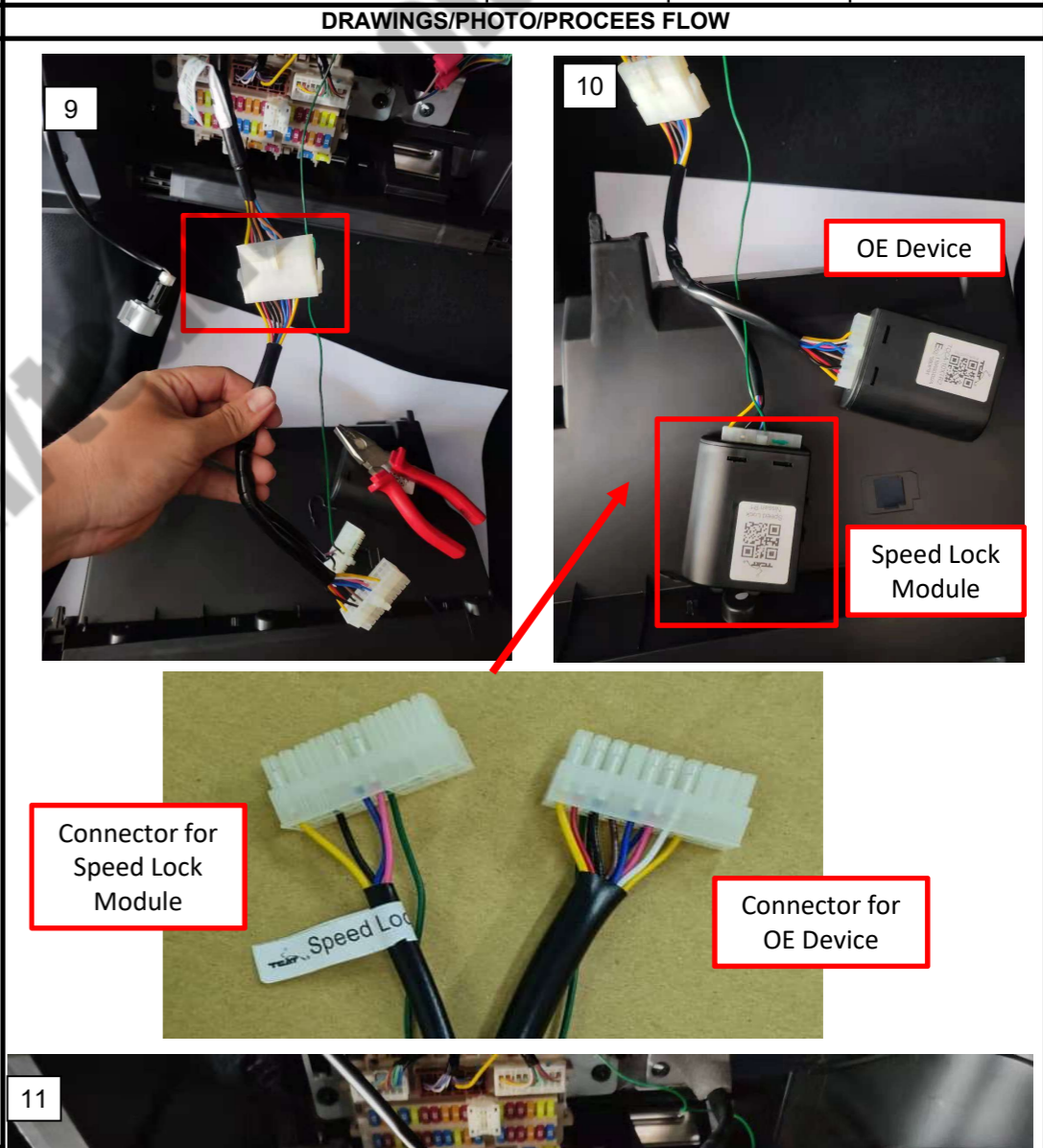
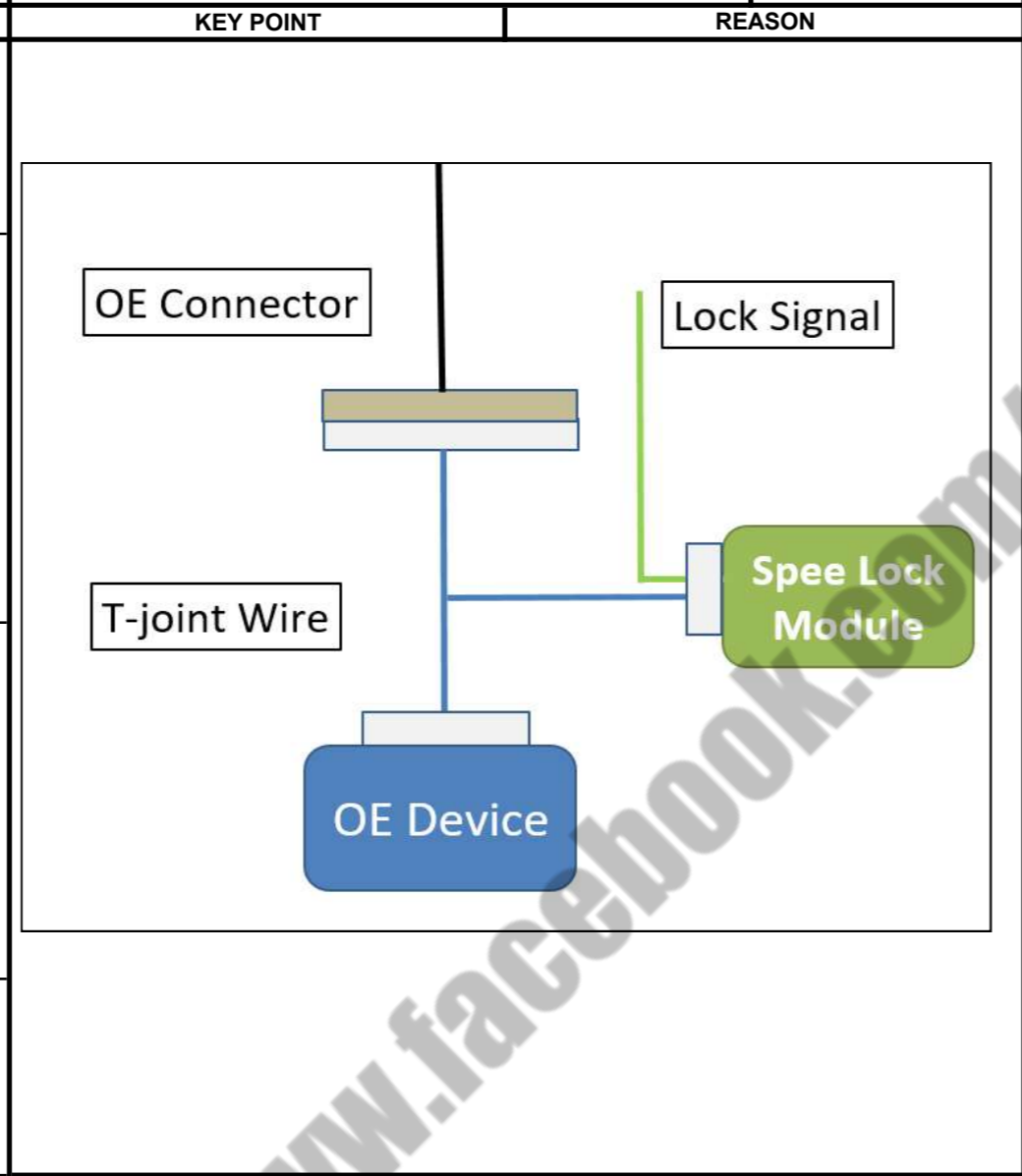

Reinstall all the parts in the reverse order of removal.
After reassembly has been completed, make sure each part functions correctly.

DOCUMENT NO.:
REVISION NO:
ISSUE DATE:

TOOLS USED
Spanner No 10
Plier
Cutter

MATERIALS USED
PARTS USED



SHEET NO.
2

2